

4 3 2 1

REVISIONS				
ZONE	LTR	DESCRIPTION	DATE	APPROVED

D

C

B

A

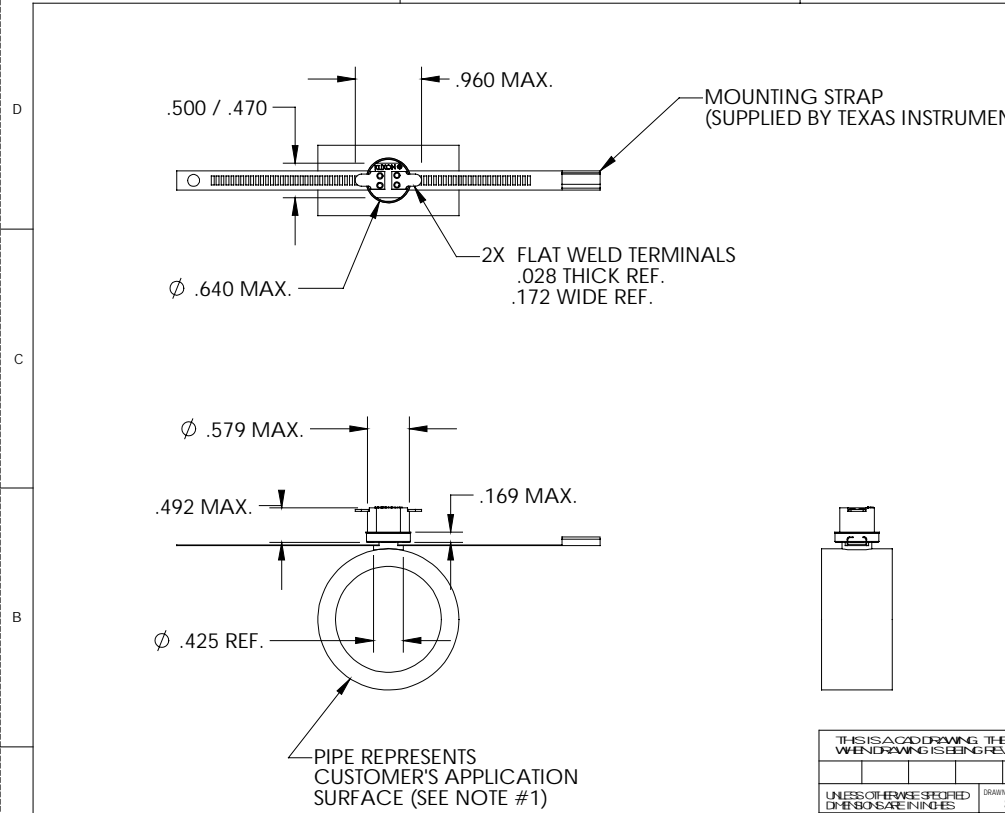

PART NO. 7BT2L15C - * - **
7BT2F15C - * - **

* "L" DESIGNATES OPEN ON TEMPERATURE RISE
"F" DESIGNATES CLOSE ON TEMPERATURE RISE

* WHEN CUSTOMER'S TEMPERATURE CHARACTERISTICS ARE ESTABLISHED, A DASH NO. WILL BE ASSIGNED, THEREBY COMPLETING THE PART NO.

** WHEN A WIRE LEAD IS DESIRED TO BE WELDED ON TO DEVICE, A SECOND DASH NO. WILL BE ASSIGNED.

- NOTES:
- 1) PIPE ADAPTER WILL CONFORM TO PIPE DIAMETERS RANGING FROM 0.75 - INCHES TO 6 - INCHES.
 - 2) ORIENTATION OF THERMOSTAT TO MOUNTING STRAP IS NOT CONTROLLED.
 - 3) DEVICE IS TO BE ATTACHED BY CUSTOMER TO PIPE SURFACE VIA TEXAS INSTRUMENTS SUPPLIED STRAP INSERTED THRU SLOT IN ADAPTER BELOW SWITCH.

UNLESS OTHERWISE SPECIFIED DIMENSIONS ARE IN INCHES					TOLERANCES ON FRACTIONS DECIMALS ANGLES				
DRAWN		S. MARQUIS		DATE		3/25/02		TEXAS INSTRUMENTS ATILEBORO MA 02705 	
ENGINEER		APPROVED		ENGINEER		APPROVED		TITLE	
MATERIAL		APPROVED		SIGNATURES ON FILE. REFER TO ELECTRONIC CHANGE NOTICE.		SIZE		CODE IDENT NO.	
						B		82647	
						SCALE		SHEET	
								7BT2-15C STYLE	

NEITHER THIS PRINT NOR THE INFORMATION CONTAINED THEREON IS TO BE USED AGAINST THE INTEREST OF TEXAS INSTRUMENTS, INC. OR AGAINST THE INTERESTS OF ANY OF ITS AFFILIATED COMPANIES OR WHOLLY OWNED SUBSIDIARIES.

FOR REFERENCE ONLY CONSULT TEXAS INSTRUMENTS CUSTOMER SERVICE FOR LATEST REVISION BEFORE USE

4 3 2 1